



ACURO™



ACURO with Parallel Interface

DESCRIPTION

The Dynapar brand ACURO Absolute Encoder offers a modern full-feature design equipped with Parallel interface.

The Acuro AI25 optical absolute industrial encoder is available in a single-turn or multi-turn version. The multi-turn design is based on a reliable high-speed gear with optical scanning and the latest generation of OptoASIC technology.

The mechanical concept is based on a double ball bearing design, which is available as a solid-shaft or hollow-shaft version in common shaft diameters.

Series AI25™

Absolute Encoder With Parallel Interface

APPLICATIONS:

Ideal for applications requiring digital feedback to be sent over an industrial bus network

- Elevators
- Machine Tool
- Assembly
- Positioning

INDUSTRIES

Manufacturing, Assembly, Material Handling and any other where precise, repeatable bidirectional position measurement is required.

FEATURES/BENEFITS

- Compact design to save valuable space
- Up to 14 Bit single-turn resolution
- 4096 revolution multi-turn resolution
- Short installation depth
- Safety through self-diagnostics
- Solid shaft and hollow shaft versions
- -40°C to +100°C Operating temperature
- Low power consumption
- Fast delivery of any model variant
- Additional field-bus and point-to-point interfaces available



ACURO with Parallel Interface

Series AI25

Absolute Encoder With Parallel Interface

SPECIFICATIONS*

STANDARD OPERATING CHARACTERISTICS

Single-turn Resolution: 10, 12, 13, 14 Bit, 360 PPR, 720 PPR
Multi-turn Resolution: 12 bit (only available with 12 bit ST resolution)
Absolute Accuracy: ± 0.01° mechanical (36 arc-sec.)
Repeatability: ± 0.002° mechanical (7.2 arc-sec.)
Code format: Binary, Gray, Gray Excess

ELECTRICAL

Connection: Cable, Conin Connector, MS Connector, Cable with Sub-D Connector (MT only)
Supply voltage: 5 VDC -5%/+10%, or 10-30 VDC
Intrinsic current consumption: 200 mA (ST), 300 mA (MT)
Output current: 30 mA per bit, short circuit protected
Frequency response: 500 kHz on single-turn, 1.5m cable*
Alarm output: NPN open collector max 5 mA
Maximum cable length: 100 m

*Data refresh rate: 70µsec is for multi-turn and single-turn with preset

Control Inputs		
Input	Logic Level	Function
Direction	1	Ascending code values when turning clockwise
	0	Descending code values when turning clockwise
Latch	1	Encoder data continuously changing at output
	0	Encoder data stored and constant at output
Tristate (ST)	1	Outputs active
	0	Outputs at high impedance (Tristate mode)
Tristate (MT)	1	Outputs at high impedance (Tristate mode)
	0	Outputs active

Status LED: Green = OK, Red = Alarm (IP64 only, not available on connector type J)
Preset Switch: Sets encoder to zero output at present mechanical position (Multi-turn IP64 only, not available on connector type J)
Control Inputs: Latch, Direction, Tri-state (see table below)

MECHANICAL

All Types
Maximum shaft speed: 10,000 RPM (continuous), 12,000 RPM (peak)
Starting torque: < 1.4 in-oz
Bearing life:
 1 x 10¹⁰ revolutions at 35% full rated shaft load
 1 x 10⁹ revolutions at 75% full rated shaft load
 1 x 10⁸ revolutions at 100% full rated shaft load
Weight (approx.): 350 g ST, 400 g MT

Shafted Types

Flange configurations: Square, Clamp, Servo
Shaft diameter: 6 mm (Servo Mount), 10 mm (Clamping Mount), 3/8" (Square Flange Mount)
Maximum shaft load:
 6 mm shaft: 13 lb axial, 24 lb radial
 10 mm shaft: 24 lb axial, 35 lb radial
 3/8" Shaft: 24 lb axial, 35 lb radial

Hubshaft Types

Flange configuration: Hubshaft with flexible tether
Accepted Mating Shaft Diameter (min./max.):
 6mm (5.984/5.996); 10mm (9.980/9.995);
 12 mm (11.976/11.994); 3/8" (.3742/.3748);
 1/2" (.4991/.4997)
Allowable Mating Shaft Movement (hubshaft only):
 +/- 1.5 mm axial, +/- 0.2 mm radial

ENVIRONMENTAL

Operating Temperature: -40 to 100° C
Storage Temperature: -40 to 100° C
Enclosure Rating: IP64 or IP67
Shock: 1,000 m/s² (6 ms)
Vibration: 100 m/s² (10 to 2,000 Hz)

* Specifications are for base models with standard features only unless otherwise noted. Specifications subject to change without notice in accordance with our DBS policy of continuous improvement. All product and brand names are trademarks of their respective owners. All rights reserved.

Dynapar™ brand ACURO™ and AI25™ are trademarks of Danaher Industrial Controls Group. All rights reserved. © 2005 DICG Corp.
 Dynapar Brand AI25 Parallel Data Sheet (8/05)

Code 1: Model	Code 2: Bits	Code 3 :Mounting	Code 4: Shaft Size	Code 5: Protocol	Code 6: Electrical	Code 7: Connector	
AI25	<input type="checkbox"/> <input type="checkbox"/> <input type="checkbox"/> <input type="checkbox"/>	<input type="checkbox"/>	<input type="checkbox"/>	<input type="checkbox"/>	<input type="checkbox"/>	<input type="checkbox"/>	
AI25 Size25 Acuro Absolute Encoder	Single-Turn 0010 10 Bit 0012 12 Bit 0013 13 Bit 0014 14 Bit 0720 720 PPR Gray Excess	Available when Code 4 is 0 or A 0 Servo* Available when Code 4 is 2 or C 1 Clamping* Available when Code 4 is 1 or B 2 Square flange**	w/o shaft seal (IP64) 0 6 mm 1 3/8" 2 10 mm 3 3/8" Hub Shaft 4 12 mm Hubshaft 5 1/2" Hubshaft 6 10 mm Hub Shaft w/ shaft seal (IP67) A 6 mm B 3/8" C 10 mm	0 Parallel Binary 1 Parallel Gray	0 5 VDC 2 10-30 VDC	0 1.5m axial cable 1 1.5m radial cable Available when Code 2 is 00XX, 0360 or 0720 6 M23 Conin 17 pin axial CW 7 M23 Conin 17 pin radial CW J 17 pin MS axial * K 19 pin Bayonet radial Available when Code 2 is 1212 A Cable 1.5m radial w/ 37 pin sub-D B Cable 1.5m axial w/37 pin sub-D <small>* Status LED and Preset Switch features not available with "J"</small>	
	Available when Code 7 is 0, 1, 6, 7 or J 0360 360 PPR Gray Excess	Available when Code 4 is 1 or B 2 Square flange**					
	Available when Code 6 is 2 Multi-Turn 1212 12 Bit Multi-Turn, 12 Bit Single-Turn	Available when Code 4 is 3, 4, 5 or 6 3 Hubshaft w/tether† * 58mm Dia. ** 2.5" Square † 63mm BC					

Absolute Encoder With BiSS Interface

Code 3: Mounting

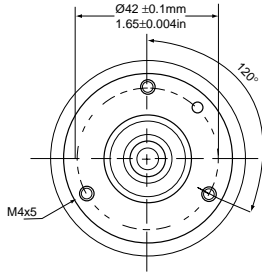

0 Servo

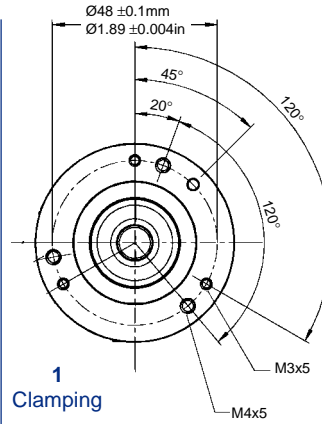
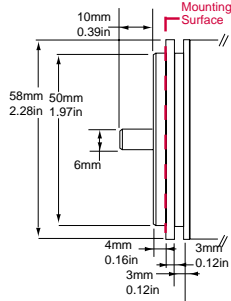

1 Clamping

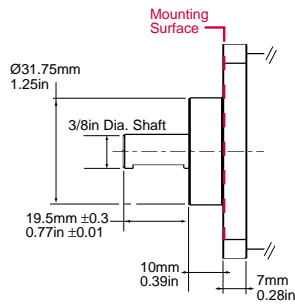
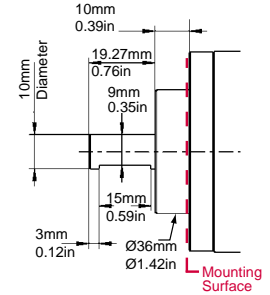

2 Square Flange

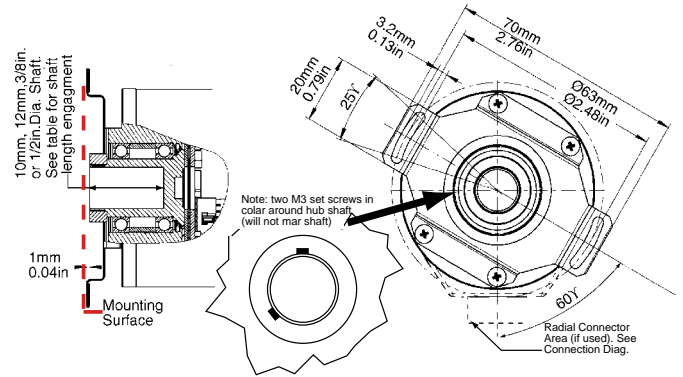
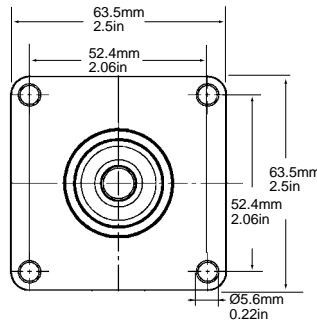

3 Hubshaft w/Tether

Hubshaft Shaft Engagement

HubShaft Diameter	Min. Shaft Length	Max. Shaft Length
10mm, 3/8"	15mm (0.59")	20mm (0.79")
12mm, 1/2"	18mm (0.71")	20mm (0.79")

Code 7: Connector

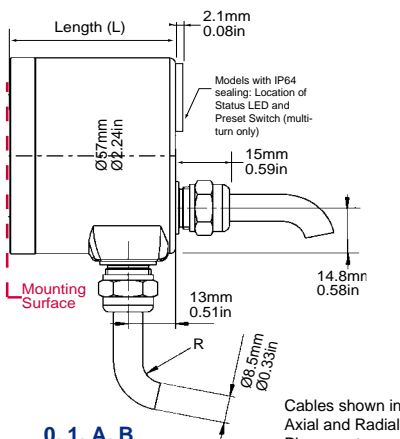

0, 1, A, B 1.5M Cable

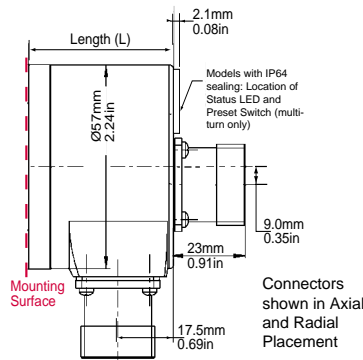

6, 7 Conin 12/17 Pin Connector

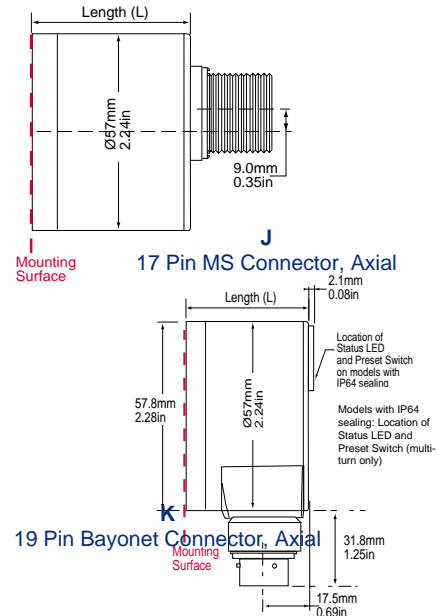

17 Pin MS Connector, Axial

19 Pin Bayonet Connector, Axial

Length (L) Mounting Surface to Rear

Mount (Code 3)	Single-Turn	Multi-Turn
(0) Servo	46.5/1.83	60.2/2.37
(1) Clamping	45.5/1.79	59.2/2.33
(2) Square Flng	45.5/1.79	59.2/2.33
(3) Hubshaft	49.9/1.96	67.1/2.64

Absolute Encoder With Parallel Interface

CONNECTOR WIRING

Explanation of Terms		
Tristate	+UB = Outputs at high impedance (Tristate mode) 0 V ²⁾ = Outputs active	
Tristate	+UB ²⁾ = Outputs active 0 V = Outputs at high impedance (Tristate-Mode)	
Latch	+UB ²⁾ = Encoder data continuously changing at output 0 V = Encoder data stored and constant at output	
Direction	+UB ²⁾ = Ascending code value when turning cw 0 V = Descending code value when turning cw	
N.C.	= Not Connected	
LSB	= Least Significant Bit	
MSB	= Most Significant Bit	
S0, S1, ...	= Data bits for resolution per turn	
M0, M1, ... (Multiturn)	= Data bits for number of turns	

2) Or unattached (floating)

PVC-cable (Singleturn) 9-12 Bit			
Color	9 Bit / 360 ³⁾	10 Bit/720 ³⁾	12 Bit
brn/gry	N.C.	N.C.	S0 (LSB)
red/blu	N.C.	N.C.	S1
vio	N.C.	S0 (LSB)	S2
wht/brn	S0 (LSB)	S1	S3
wht/grn	S1	S2	S4
wht/yel	S2	S3	S5
wht/gry	S3	S4	S6
wht/pnk	S4	S5	S7
wht/blu	S5	S6	S8
wht/red	S6	S7	S9
wht/blk	S7	S8	S10
brn/grn	S8 (MSB)	S9 (MSB)	S11 (MSB)
yel	Tristate D0...D8	Tristate D0...D9	Tristate D0.. D11
pnk	Latch ⁴⁾	Latch ⁴⁾	Latch ⁴⁾
grn	Direction	Direction	Direction
blk	0 V	0 V	0 V
red	5/10...30VDC	5/10...30VDC	5/10...30VDC
brn	Alarm	Alarm	Alarm

3) Increments 4) Binary Only

Connector 17pol. (CONIN) 9-12 Bit			
Pin	9 Bit / 360 ³⁾	10 Bit / 720 ³⁾	12 Bit
1	S0 (LSB)	S0 (LSB)	S0 (LSB)
2	S1	S1	S1
3	S2	S2	S2
4	S3	S3	S3
5	S4	S4	S4
6	S5	S5	S5
7	S6	S6	S6
8	S7	S7	S7
9	S8 (MSB)	S8	S8
10	N.C.	S9 (MSB)	S9
11	N.C.	N.C.	S10
12	Tristate S0...S8	Tristate S0...S9	S11 (MSB)
13	Latch ⁴⁾	Latch ⁴⁾	Latch ⁴⁾
14	Direction	Direction	Direction
15	0 V	0 V	0 V
16	5/10...30VDC	5/10...30VDC	5/10...30VDC
17	Alarm	Alarm	Alarm

3) Increments 4) Binary Only

Connector 17pol. (CONIN) 13-14 Bit		
Pin	13 Bit	14 Bit
1	S12 (MSB)	S13 (MSB)
2	S11	S12
3	S10	S11
4	S9	S10
5	S8	S9
6	S7	S8
7	S6	S7
8	S5	S6
9	S4	S5
10	S3	S4
11	S2	S3
12	S1	S2
13	S0 (LSB)	S1
14	Direction	S0 (LSB)
15	0 V	0 V
16	5/10...30VDC	5/10...30VDC
17	Latch (Binarycode) Alarm (Graycode)	Latch (Binarycode) Alarm (Graycode)

TPE-cable (Multiturn 13-14 Bit) 37 pol. Sub-D		
Color	Pin	
brn	2	S0
grn	21	S1
yel	3	S2
gry	22	S3
pnk	4	S4
vio	23	S5
gry/pnk	5	S6
red/blu	24	S7
wht/grn	6	S8
brn/grn	25	S9
wht/yel	7	S10
yel/brn	26	S11
wht/gry	8	M0
gry/brn	27	M1
wht/pnk	9	M2
pnk/brn	28	M3
wht/blu	14	M4
brn/blu	33	M5
wht/red	15	M6
brn/red	34	M7
wht/blk	16	M8
brn/blk	35	M9
gry/grn	17	M10
yel/gry	36	M11
pnk/grn	18	Alarm
yel/pnk	10	Direction
grn/blu	30	Latch
yel/blu	12	Tristate
red	13	10...30 VDC
wht	31	10...30 VDC
blu	1	0 V
blk	20	0 V

Absolute Encoder With Parallel Interface

MS style 17 pin connectors					
Pin	Function		107865 Cable Accessory* Color Code	14 BIT	13 BIT
	12 Bit 4096 CPR	10 Bit 1024 CPR			
A	Vin		Red	D13 (MSB)	D12 (MSB)
B	N.C.		Violet	D12	D11
C	Latch (binary only)		Green	D11	D10
D	Direction		Orange	D10	D9
E	S1	N.C.	White	D9	D8
F	S3	S1	White/Brown	D8	D7
G	S5	S3	White/Orange	D7	D6
H	S7	S5	White/Green	D6	D5
J	S8	S6	White/Blue	D5	D4
K	S9	S7	White/Violet	D4	D3
L	S11 (MSB)	S9 (MSB)	White/Black/Brown	D3	D2
M	GND		Black	D2	D1
N	S4	S2	White/Red	D1	D0 (LSB)
P	S0 (LSB)	N.C.	Gray	D0 (LSB)	Direction
R	S2	S0 (LSB)	White/Black	GND	GND
S	S6	S4	White/Yellow	Latch	Latch
T	S10	S8	White/Grey	Vin	Vin
10ft Cable # 107865-0010				NA	
Mating Connector: MS 17 pin style MS3106A-20-29S part # MCN-N8					
*This is a mating connector/cable assembly. Color coding information is provides here for reference					

PVC-cable (Singleturn 13-14 Bit)		
Color	13 Bit	14 Bit
gry/pnk	N.C	S0 (LSB)
brn/yel	S0 (LSB)	S1
brn/gry	S1	S2
red/blu	S2	S3
vio	S3	S4
wht/brn	S4	S5
wht/grn	S5	S6
wht/yel	S6	S7
wht/gry	S7	S8
wht/pnk	S8	S9
wht/blu	S9	S10
wht/red	S10	S11
wht/blk	S11	S12
brn/grn	S12 (MSB)	S13 (MSB)
yel	Tristate S0...S12	Tristate S0...S13
pnk	Latch ⁴⁾	Latch ⁴⁾
grn	Direction	Direction
blk	0 V	0 V
red	5/10...30VDC	5/10...30VDC
brn	Alarm	Alarm

4) Binary Only

Bayonet style 19 pin connectors							
Pin	Function 14 Bit 16384 CPR	112077 Cable Accessory* Color Code	Function 13 it 8192 CPR	112076 Cable Accessory* Color Code	Function		110158 Cable Accessory* Color Code
					12 Bit 4096 CPR	10 Bit 1024 CPR	
A	S13 (MSB)	White/Black/Brown	S12	White/Black/Brown	S11 (MSB)	S9 (MSB)	White/Black/Brown
B	S12	White/Grey	S11	White/Grey	S10	S8	White/Grey
C	S11	White/Violet	S10	White/Violet	S9	S7	White/Violet
D	S10	White/Blue	S9	White/Blue	S8	S6	White/Blue
E	S9	White/Green	S8	White/Green	S7	S5	White/Green
F	S8	White/Orange	S7	White/Orange	S6	S4	White/Orange
G	S7	White/Yellow	S6	White/Yellow	S5	S3	White/Yellow
H	S6	White/Red	S5	White/Red	S4	S2	White/Red
J	S5	White/Brown	S4	White/Brown	S3	S1	White/Brown
K	S4	White/Black	S3	White/Black	S2	S0 (LSB)	White/Black
L	S3	Brown	S2	Blue	S1	N.C.	White
M	S2	Blue	S1	White	S0 (LSB)	N.C.	Grey
N	S1	White	S0 (LSB)	Grey	N.C	N.C.	
P	S0 (LSB)	Grey	GND	Black	GND		Black
R	Direction	Orange	Direction	Orange	Direction		Orange
S	Case	Violet	Case	Violet	Case		Violet
T	GND	Black	GND	Yellow	GND		Yellow
U	Latch	Green	Latch	Green	Latch (binary only)		Green
V	Vin	Red	Vin	Red	Vin		Red
10ft Cable # 112077-0010			10ft Cable # 112076-0010		10ft Cable # 110158-0010		
Mating Connector: 19 pin Bayonet style PT06E-14-19S part # 606219-0001							

*This is a mating connector/cable assembly. Color coding information is provided here for reference

Worldwide Brands:

Dynapar™

Eagle Signal™

Harowe™

Hengstler™

NorthStar™

Veeder-Root™



**A division of
Danaher, a
Fortune 500
company with
offices in 30
countries around
the world.**

More Available. With factories around the world, global sales and applications support, and an expansive network of distributors, we stay close to our customers - shortening lead times and fostering responsiveness. Three-day lead time is standard, with same-day shipments available on many of our products.

More Selection. We have a broad selection of controllers to meet application requirements in a variety of industries. User-configurable, accurate and flexible, with low, mid, or high level performance ranges, our controller products meet your system and budgetary requirements.

More Reliable. Our experience with more than 25,000 customers has taught us to design controllers that are reliable and durable, with quality standards that meet six sigma requirements.

For additional information or a full-line catalog, contact DICG Customer Service or visit our web site.

* Specifications are for base models with standard features only unless otherwise noted. Specifications subject to change without notice in accordance with our DBS policy of continuous improvement. All product and brand names are trademarks of their respective owners. All rights reserved.

Dynapar™ brand, ACURO™ and AI25™ are trademarks of Danaher Industrial Controls Group. All rights reserved.

© 2005 DICG Corp.

Headquarters: 1675 Delany Road • Gurnee, IL 60031-1282 • USA
Phone: +1 847.662.2666 • Fax: +1 847.662.6633

Dynapar Brand AI25 Parallel Data Sheet (8/05)

Satellite Locations:
North America: North Carolina, South Carolina, Connecticut, Massachusetts, New York, Canada, British Virgin Islands • Europe: United Kingdom, Italy, France, Germany, Spain, Slovakia • Latin America: Brazil • Asia: China, Japan, Korea, Singapore

Customer Service:

Tel.: +1.800.873.8731

Fax: +1.847.662.4150

dynapar.custserv@dancon.com

Technical Support

Tel.: +1.800.234.8731

Fax: +1.847.782.5277

dynapar.techsupport@dancon.com



www.feedbackdevices.com • www.danaherindustrialcontrols.com

Factory Automation Worldwide Brands: *Dynapar™* • *Eagle Signal™* • *Harowe™* • *Hengstler™* • *NorthStar™* • *Veeder-Root™*