

RIM Tach HS85

- *Mounts easily to roller, sleeve, or ball bearing motors and can be used on non-motor applications, such as line shafts and conveyor shafts*
- *Accepts motor shafts sizes up to 4.500" (115mm) dia., including tapered shafts*

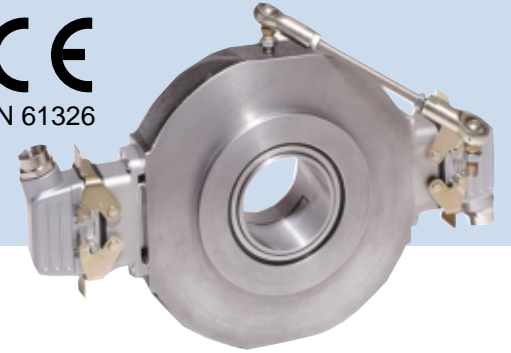

APPLICATION/INDUSTRY

The © NorthStar brand RIM Tach HS85 is a mill duty, digital tachometer that accommodates large thru-shaft sizes (up to 4.5 inches or 115mm) and can easily mount to most AC or DC fan cooled motors. This digital tachometer offers the reliability, resolution, and flexibility characteristics for which NorthStar products are known.

DESCRIPTION

The HS85 digital tachometer incorporates state-of-the-art magnetoresistive sensing technology. The magnetically encoded signals provide pulse codes of A, B, and an optional index pulse Z, with complements (A, B, Z). These signals are solid for the life of the encoder. They do not exhibit the unreliable signal drift that requires a fault check on other digital tachometers. In addition, this technology is immune to common contaminants such as water, oil, grease, dirt, vibration, and overall harsh conditions of operation.

The HS85 was created as a solution to roller or sleeve bearing motors with excessive axial and radial play. This digital tachometer is ruggedly designed with steel flanges, heavy duty motor style bearings, and cast iron housing. The mill duty construction is ideal for motor and non-motor applications, or where the motor casting is otherwise unavailable. As an example, the HS85 is perfect for mounting as a line shaft reference encoder. By virtue of design, the HS85 is more forgiving of older motors which are unable to hold precise tolerances.

The HS85 is shipped pre-assembled. The installation is quick and easy; just slip the unit over the motor shaft, tighten the clamp, and add the anti-rotation arm. The sensor alignment of the HS85 is entirely independent of the motor frame. Wiring is simple due to the industrial duty connectors. No field soldering or crimp pins are required. Simply strip conductor ends, insert and tighten the connector screws. The interchangeable stainless steel sensor modules are available in a wide variety of pulse counts. There are no field gap checks, axial alignments, or radial run-out checks required.

FEATURES AND BENEFITS

- Easy Installation
- Rugged, cast-iron and steel enclosure and zero-speed, magnetoresistive sensing technology
- immune to grease, salt water, dust, and other contaminants
- Heavy duty, double sealed, deep groove, radial ball bearings to tolerate axial and radial runouts

SPECIFICATIONS

STANDARD OPERATING CHARACTERISTICS

Code: Incremental
Pulses per Revolution: 60-2048
Phasing Sense: A leads B for Counter-Clockwise rotation (CCW) viewing encoder-mounted end
Quadrature Phasing: 90° ± 22°
Symmetry: 180° ± 54°
Index: 270° gated to falling B edge

ELECTRICAL

Input Voltage Requirement: 5-15 or 15-26 Volts DC
Current Requirement:
 With Electrical Option L: 45mA typical per sensor module plus line driver load
 With Electrical Option R: 65mA typical per sensor module plus line driver load
 With Electrical Option 5: 65mA typical per sensor module plus line driver load
Output Signals:
 With Elec Option L: 5-15 V Line Driver, 150mA
 With Elec Option R: 15 V Line Driver, 150mA
 With Elec Option 5: 5V Line Driver, 150mA
Electrical Immunity: 2kV ESD, Reverse Polarity, Short Circuit
Connector: 10 pin industrial duty latching, sealed NEMA 4 & 12, IP65; MS connector or pig-tail

ELECTRICAL CONNECTIONS

Signal	Connector Pin	Pigtail Cable	MS 3102E18-IT#
Common	1	Black	A
B	2	Green	E
A	3	Blue	D
Z *	4	Violet	C
No Connection	5	—	—
Vcc	6	Red	B
B	7	Yellow	H
A̅	8	Gray	G
Z *	9	Orange	I
Shield	10	Braid	J

* Index (Z) optional. See Ordering Information

MECHANICAL

Shaft Speed: 3,600 RPM
Mounting Configuration: Hollow Shaft mount with Anti-Rotation Tether
Housing Material: Cast Iron/Stainless Steel
Acceleration Rate: 3,600 rpm/sec max
Allowable Shaft End-Play: 0.025" (Subject to RPM Limitation)
Allowable Shaft Runout: 0.010" TIR (Subject to RPM Limitation)

ENVIRONMENTAL

Operating Temperature Range: -20°C to +70°C
Storage Temperature Range: -40°C to +120°C
Humidity: to 98% RH (non-condensing)
Shock (Sensor Module): 1 meter drop test, 30 G's Min
Vibration: 18 G's @ 5-2000 Hz spectrum

Specifications are for base models with standard features only unless otherwise noted. Specifications subject to change without notice in accordance with our DBS policy of continuous improvement. All product and brand names are trademarks of their respective owners. All rights reserved.

NorthStar™ brand is a trademark of Dynapar. All rights reserved.

© 2007-2008 Dynapar

NorthStar brand HS85 Data Sheet (02/08)

DIMENSIONS

inches [mm]

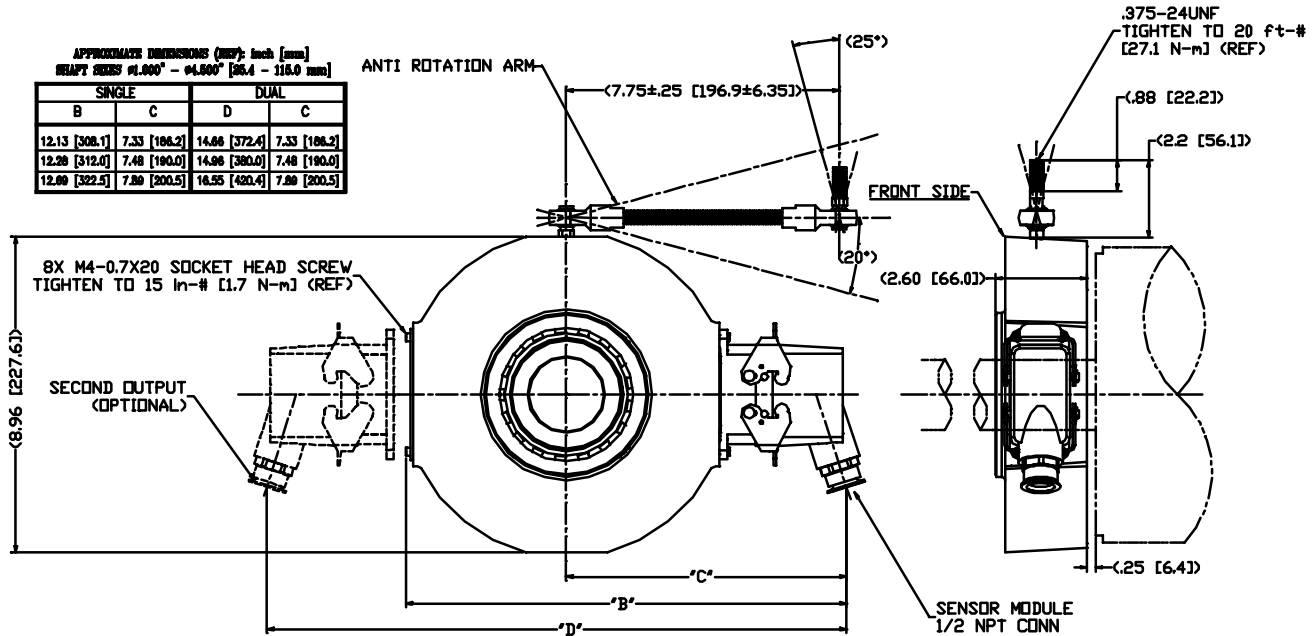

APPROXIMATE DIMENSIONS (REF): inch [mm]
SERIES #1.000" - #4.000" [25.4 - 116.0 mm]

SINGLE		DUAL	
B	C	D	C
12.13 [308.1]	7.33 [186.2]	14.86 [372.4]	7.33 [186.2]
12.28 [312.0]	7.48 [190.0]	14.98 [380.0]	7.48 [190.0]
12.60 [322.5]	7.80 [200.5]	16.55 [420.4]	7.80 [200.5]

ORDERING INFORMATION

Code 1: Model	Code 2: PPR	Code 3: Index	Code 4: Wheel Bore	Code 5: Output	Code 6: Electrical	Code 7: Termination
H8	<input type="checkbox"/>	<input type="checkbox"/>	<input type="checkbox"/>	<input type="checkbox"/>	<input type="checkbox"/>	<input type="checkbox"/>

Ordering Information						
H8 Hollow Shaft	0060 0064 0075 0120 0128 0150 0240 0256	0300 0480 0512 0600 0960 1024 1200 2048	L No Index Available when Code 2 is 0480, 0512, 0600, 0960, 1024, 1200 or 2048 Z Differential Index (Z, Z)	Thru-bores T01 1-1/8" bore T02 1-3/8" bore T03 1-5/8" bore T04 1-7/8" bore T05 2.00" bore T06 2-1/8" bore T07 2-1/4" bore T08 2-3/8" bore T09 2-1/2" bore T10 2-7/8" bore Bores with 1.25" per foot taper P01 1-1/8" bore P02 1-3/8" bore P03 1-5/8" bore P04 1-7/8" bore P05 2.00" bore P06 2-1/8" bore P07 2-1/4" bore P08 2-3/8" bore P09 2-1/2" bore P10 2-7/8" bore Additional Shaft Sizes Up to 4.50" Maximum Available (thru and taper shaft) Call factory for details	1 Single 2 Dual (Isolated) Differential, bidirectional signals (A, A, B, B)	L 5-15V in, 5-15V Line Driver (4428) out R 15-26V in, 15V Line Driver (4428) out 5 5-15V in, 5V Line Driver (4428) out
						C Latching Industrial Connector with 1/2" NPT M 10 pin MS Connector P 18" Pigtail

Spare sensor module Use "NS" followed by Code 1 (Model) & Code 2 (PPR) & Code 3 (Index) & Code 6 (Electrical) & Code 7 (Termination). Example: NSH80512ZLC

Spare Mating Connector: Use "NS" followed by Code 1 (Model) & Code 7 (Termination). Example: NSH8C

5 foot Interface Cable: RIMCABLEDB10005. Other Length: final 4 digits is length in 5 ft increments. Example RIMCABLEDB10065 is 65 feet.