

NEW



Series HSD25

- *Single or Dual output*
- *ATEX Certification available for Intrinsically Safe application*
- *High Resolution Unbreakable Disk*
- *Industrial Duty Connector*
- *NEMA 4X, 6 / IP66, 67 Rated*
- *Nickel or Stainless Steel Housing available*
- *Two Year Warranty*

Harsh-Duty Optical Hub Shaft Encoder

DESCRIPTION

NorthStar's HSD25 Harsh-Duty Optical Hub Shaft Encoder accepts up to 0.75" diameter shafts and operates reliably from -40 to +100°C. The Hard Anodized finish encoder exceeds IP66/IP67 and NEMA 6 enclosure requirements.

This robust encoder is also available in Stainless Steel to meet NEMA 4x and 6P requirements and its sealed housing allows the Encoder to be operated when regulatory washdown and high pressure steam or caustic chemicals are required. Utilization of an advanced Opto ASIC with innovative packaging techniques enables the encoder to operate in high shock and vibration environments.

The HSD25 is also available in an Intrinsically Safe version certified to ATEX EEx ia IIB T4 when used with the appropriate IS barrier.

APPLICATIONS:

The HSD25 Harsh-Duty Optical Encoder features simple installation on motor or machine hub shafts. It is often mounted on the back of motors where encoder feedback is needed in harsh environment applications. Available housing options make it ideal use in corrosive environments that demand heavy washdown protection. ATEX certification is also available for intrinsically safe applications.

- Converting Machinery
- Material Handling
- Packaging Equipment
- Oil Field Exploration
- Processing Equipment

INDUSTRIES

Chemical, Food & Beverage, Oil & Gas, Paper, Steel and any other where a precise encoder is needed to operate in harsh environments.

FEATURES/BENEFITS

Mechanical and Environmental

- Unbreakable code disk
- Hub Shaft mounting
- Heavy duty shaft seals
- Sealed connector

Electrical

- Cast housing maximizes noise immunity and durability

Harsh-Duty Optical Hub Shaft Encoder

Series HSD25

Harsh-Duty... Meets Stringent Washdown Requirements

SPECIFICATIONS*

STANDARD OPERATING CHARACTERISTICS

Code: Incremental
Resolution: 1 to 3600 PPR (pulses/revolution)
Format: Two channel quadrature (AB) with optional Index (Z), and complementary outputs
Phase Sense: A leads B for CCW shaft rotation viewing the shaft clamp end of the encoder
Quadrature Phasing: For resolutions to 625PPR: 90° ± 15° electrical; For resolutions over 625 PPR: 90° ± 30° electrical
Symmetry:
 For resolutions to 1024PPR: 180° ± 18° electrical
 For resolutions over 1024PPR: 180° ± 25° electrical
Waveforms: Squarewave with rise and fall times less than 1 microsecond into a load capacitance of 1000 pf

ELECTRICAL

Input Power: 5-26VDC. 50 mA max., not including output loads. ATEX: 5VDC, 7-26VDC
Outputs: 2N2222, ET7272, ET7273
Frequency Response: 125 kHz (data & index)
Termination: 6, 7, or 10 pin MS Connector; 5 or 8 Pin M12 Connector; Cable exit w/seal;
Mating Connector:
 6 pin, style MS3106A-14S-6S (MCN-N4);
 7 pin, style MS3106A-16S-1S (MCN-N5);
 10 pin, style MS3106A-18-1S (MCN-N6)
 5 pin, style M12 Cable with Connector Available
 8 pin, style M12 Cable with Connector Available

ELECTRICAL CONNECTIONS

6, 7 & 10 Pin MS Connectors and Cables

Connector & mate/accessory cable assembly pin numbers and wire color information is provided here for reference. Models with direct cable exit carry the color coding as shown in the right hand column.

Encoder Function	Cable # 108594-6 Pin Single Ended		Cable # 108595-7 Pin Single Ended		Cable # 108596-7 Pin Dif Line Drv w/o Idx		Cable # 1400635-10 Pin Dif Line Drv w/Idx		Bayonet Connector 10 Pin Dif Line Drv w/Idx	Cable #108615-* 12 Pin CCW		Cable Exit with Seal
	Pin	Wire Color	Pin	Wire Color	Pin	Wire Color	Pin	Wire Color		Pin	Wire Color	
Sig. A	E	BRN	A	BRN	A	BRN	A	BRN	A	5	BRN	GREEN
Sig. B	D	ORG	B	ORG	B	ORG	B	ORG	B	8	ORN	BLUE
Sig. Z	C	YEL	C	YEL	—	—	C	YEL	C	3	YEL	ORANGE
Power +V	B	RED	D	RED	D	RED	D	RED	D	12	RED	RED
Com	A	BLK	F	BLK	F	BLK	F	BLK	F	10	BLK	BLACK
Case	—	—	G	GRN	G	GRN	G	GRN	G	9	—	WHITE
N/C-SLD	F	—	E	—	—	—	E	—	E	7	—	—
Sig. A	—	—	—	—	C	BRN/WHT	H	BRN/WHT	H	6	BRN/WHT	VIOLET
Sig. B	—	—	—	—	E	ORG/WHT	I	ORG/WHT	J	1	ORN/WHT	BROWN
Sig. Z	—	—	—	—	—	—	J	YEL/WHT	K	4	YEL/WHT	YELLOW
0 Volt Sense	—	—	—	—	—	—	—	—	—	2	GRN	—
5 Volt Sense	—	—	—	—	—	—	—	—	—	11	BLK/WHT	—

Note: "MS" type mating connectors and prebuilt cables are rated NEMA 12. "M12" Cable assemblies are rated IP67

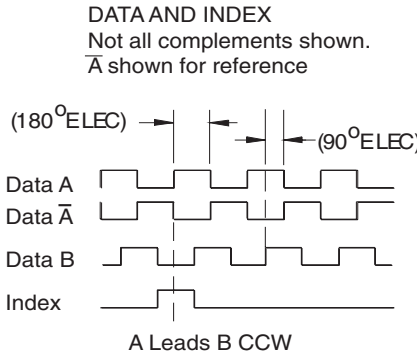

MECHANICAL

Shaft Material: 303 stainless steel (passivated)
Bore Diameter: 3/8", 10mm, 1/2", 5/8", 3/4". Insulated inserts provided
Bore runout: 0.0005 TIR at midpoint
Starting torque: 6.5 in-oz. maximum (at 25°C)
Bearings: 61805-2RZ
Bearing life: 5 x 10⁸ revs at rated shaft Loading, 5 x 10¹¹ revs at 10% of rated shaft loading. (manufacturers' specs)
Housing and cover: Hard Anodized Aluminum. Also available in Electroless Nickel finish and Stainless Steel. Tether Available
Disc material: Metal or mylar
Weight: 20 ounces, typical

ENVIRONMENTAL

Operating Temperature: -40 to 100°C
Operating Temperature ATEX: -40 to 80°C
Storage temperature: -40 to 100°C
Shock: 50G's for 11msec duration
Vibration: 5 to 2000Hz @ 20 G's
Humidity: 100%
Enclosure Rating: NEMA 4X, NEMA 6, IP66, IP67 (NEMA 6P upon request)
 Note: "MS" type mating connectors and prebuilt cables are rated NEMA 12. "M12" Cable assemblies are rated IP67

* Specifications are for base models with standard features only unless otherwise noted. Specifications subject to change without notice in accordance with our DBS policy of continuous improvement. All product and brand names are trademarks of their respective owners. All rights reserved.

5 & 8 Pin M12 Accessory Cables when Code 6=H or J

Connector pin numbers and cable assembly wire color information is provided here for reference.

Encoder Function	Cable # 112859-5 Pin Single Ended		Cable # 112860-8 Pin Single Ended		Cable # 112860-8 Pin Differential	
	Pin	Wire Color	Pin	Wire Color	Pin	Wire Color
Sig. A	4	BLK	1	BRN	1	BRN
Sig. B	2	WHT	4	ORG	4	ORG
*Sig. Z	5	GRY	6	YEL	6	YEL
Power +V	1	BRN	2	RED	2	RED
Com	3	BLU	7	BLK	7	BLK
Sig. A-bar	-	-	-	-	3	BRN/WHT
Sig. B-bar	-	-	-	-	5	ORG/WHT
*Sig. Z-bar	-	-	-	-	8	YEL/WHT

* Index not provided on all models. See ordering information

Cable Configuration: PVC jacket, 105 °C rated, overall foil shield; 24 AWG conductors, minimum

Harsh-Duty... Meets Stringent Washdown Requirements

DIMENSIONS inches [mm]

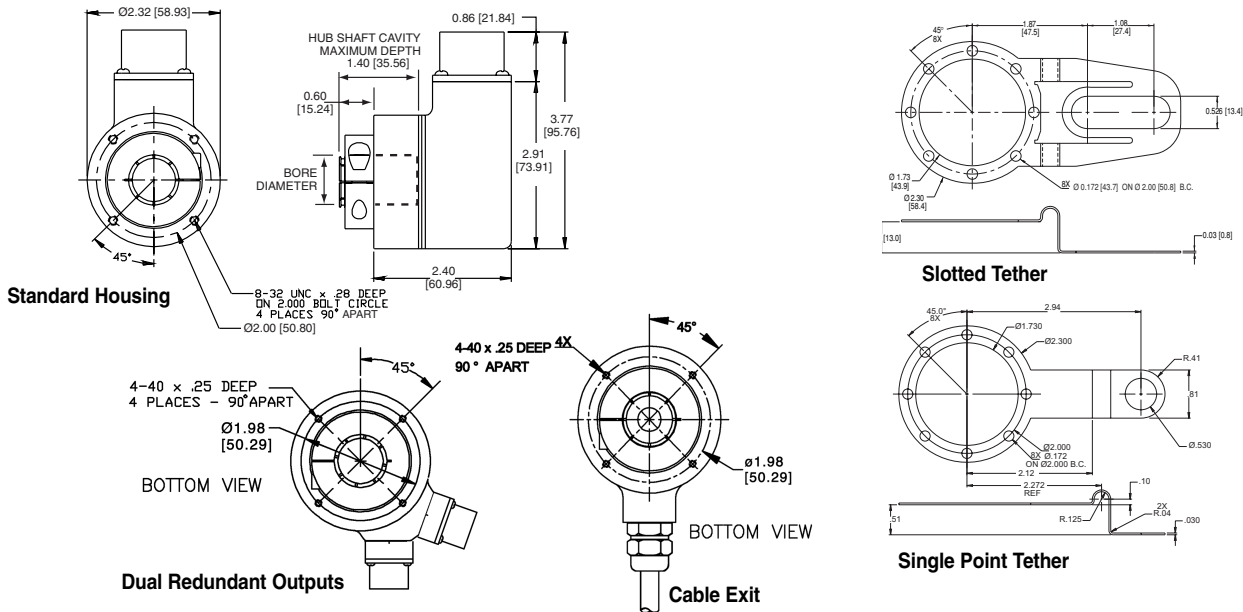

ORDERING INFORMATION

Code 1: Model	Code 2: PPR	Code 3: Bore Size	Code 4: Format	Code 5: Output	Code 6: Termination	Code 7: Safety	Code 8: Housing/Tether
HSD25	<input type="checkbox"/>	<input type="checkbox"/>	<input type="checkbox"/>	<input type="checkbox"/>	<input type="checkbox"/>	<input type="checkbox"/>	<input type="checkbox"/>

Ordering Information							
HSD25 Size 23 Harsh-Duty, Optical Hub Shaft Encoder	0001 0500 0010 0512 0024 0600 0025 0625 0035 0720 0040 1000 0060 1024 0100 1200 0120 1250 0192 1440 0200 2000 0240 2048 0250 2500 0256 2600 0300 2540 0360 3600	4 3/8" 5 10 mm 6 12 mm 7 1/2" 8 5/8" C 3/4"	0 single ended, unidirectional (A) 1 single ended, bidirectional (AB) 2 single ended, bidirectional with index (ABZ) 3 differential, bidirectional (AA BB) available when Code 5 is 3 or 4 and Code 8 is 0, 1, 2, C, D, E, 6, 7 or 8: 4 differential, bidirectional with index (AA BB ZZ)	0 5-26V in, 5-26V Open Collector out (7273) 2 5-26V in, 5-26V Push-Pull out F 5-26V in, 5-26V Open Collector out (2222) G 5-26V in, 5-26V Open Collector out with 2.2 kΩ Pullups (2222) available when: Code 4 is 3, or 4 3 5-26V in, 5-26V Differential Line Driver out (7272) 4 5-26V in, 5V Differential Line Driver out (7272)	0 6 pin connector 1 7 pin connector 2 10 pin connector 3 12 pin connector 4 10 pin Bayonet connector 5 6 pin connector, plus mating connector 6 7 pin connector, plus mating connector 7 10 pin connector, plus mating connector 8 12 pin connector, plus mating connector A 18" (.5m) cable B 36" (1m) cable C 72" (2m) cable D 10' (3m) cable E 4m cable F 13' (.3m) cable with 10 pin connector plus mating connector G 13' (.3m) cable J 8 Pin M12 Connector available when Code 5 is 0, 2, F or G H 5 Pin M12 Connector	0 No ATEX 1 ATEX Type 1* Option available when: Code 5 is 0, 2, 3, F or G 2 ATEX Type 2* Option available when: Code 5 is 4 3 ATEX Type 3* Option	0 Cast Alum Housing; slotted tether 1 Nickel Housing; slotted tether 2 Stainless Housing; slotted tether 3 Redundant Outputs (Dual Connector Housing); slotted tether 4 Nickel Housing; Redundant Outputs; slotted tether 5 Stainless Housing, Redundant Outputs; slotted-tether C Cast Alum Housing; single-point tether D Nickel Housing; single-point tether E Stainless Housing; single-point tether F Redundant Outputs (Dual Connector Housing); single-point tether G Nickel Housing; Redundant Outputs; single-point tether H Stainless Housing, Redundant Outputs; single-point tether 6 Same as "0" but no tether** 7 Same as "1" but no tether** 8 Same as "2" but no tether** 9 Same as "3" but no tether** A Same as "4" but no tether** B Same as "5" but no tether**

**Note: Tether may be required for proper encoder operation and may be supplied by the customer or ordered as the following accessories:

- 113764-0001 Single Point Tether Kit
- 113766-0001 Slotted Tether Kit

*Note: Available ATEX Certified Options
ATEX Type 1: ATEX Certified; 5V in, 5V out only
ATEX Type 2: ATEX Certified; 7-26V in, 7-26V out
ATEX Type 3: ATEX Certified; 7-26V in, 5V out
 NOTE: When selecting ATEX models, ATEX voltages replace those shown in Code 5.

† NOTE: Simultaneous use of redundant outputs may void ATEX certification. Consult factory for details.

Worldwide Brands:

Dynapar™

Harowe™

Hengstler™

NorthStar™

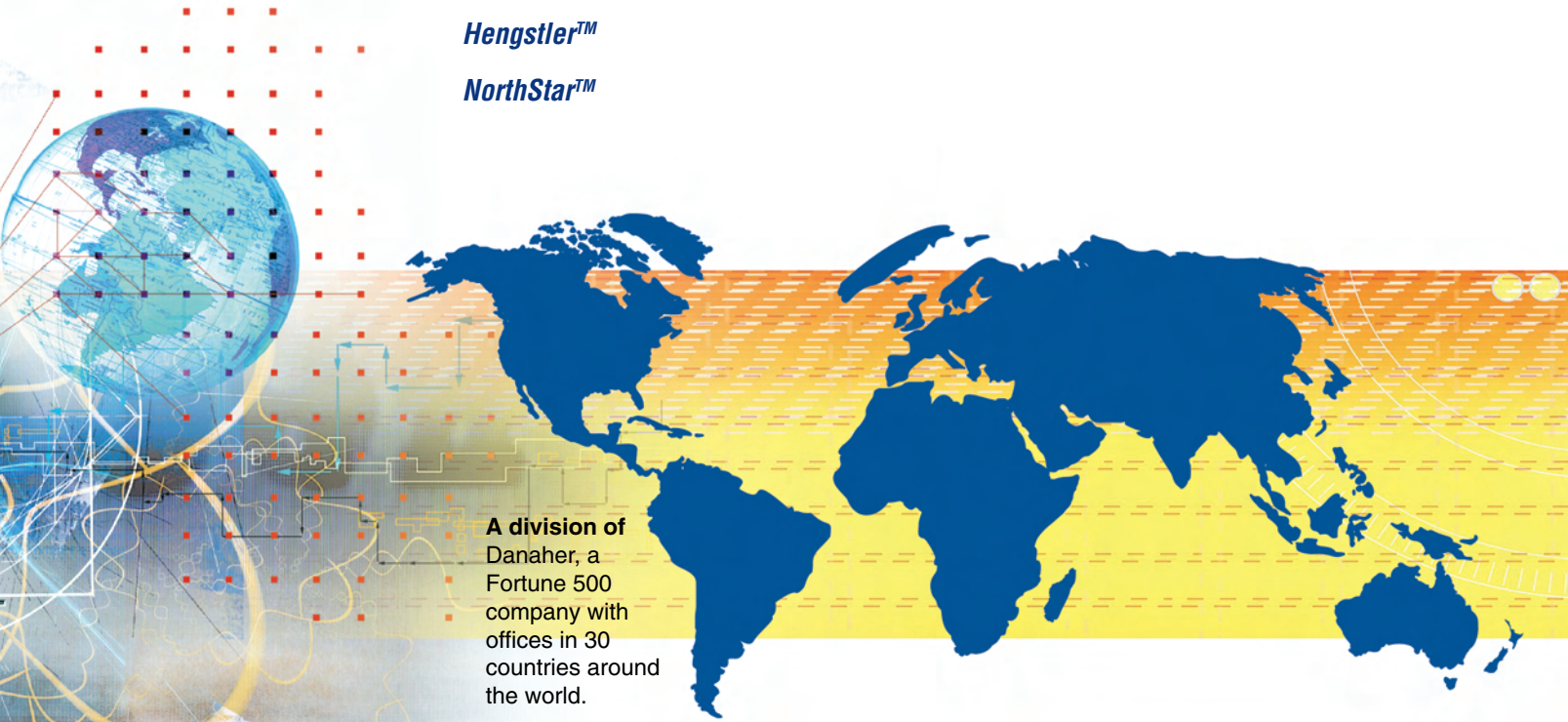

**A division of
Danaher, a
Fortune 500
company with
offices in 30
countries around
the world.**

More Available. With factories around the world, global sales and applications support, and an expansive network of distributors, we stay close to our customers - shortening lead times and fostering responsiveness. Three-day lead time is standard, with same-day shipments available on many of our products.

More Selection. We have a broad selection of controllers to meet application requirements in a variety of industries. User-configurable, accurate and flexible, with low, mid, or high level performance ranges, our controller products meet your system and budgetary requirements.

More Reliable. Our experience with more than 25,000 customers has taught us to design controllers that are reliable and durable, with quality standards that meet six sigma requirements.

For additional information or a full-line catalog, contact DICG Customer Service or visit our web site.

* Specifications are for base models with standard features only unless otherwise noted. Specifications subject to change without notice in accordance with our DBS policy of continuous improvement. All product and brand names are trademarks of their respective owners. All rights reserved.

NorthStar™ brand is a trademark of Dynapar. All rights reserved.

HSD25 Data Sheet (08/09) ©2009 Dynapar

Headquarters: 1675 Delany Road • Gurnee, IL 60031-1282 • USA
Phone: +1 847.662.2666 • Fax: +1 847.662.6633

Satellite Locations:

North America: North Carolina, South Carolina, Connecticut, Massachusetts, New York, Canada, British Virgin Islands • Europe: United Kingdom, Italy, France, Germany, Spain, Slovakia • Latin America: Brazil • Asia: China, Japan, Korea, Singapore



Factory Automation Worldwide Brands: Dynapar™ • Harowe™ • Hengstler™ • NorthStar™

www.dynapar.com

Customer Service:

Tel.: +1.800.873.8731

Fax: +1.847.662.4150

northstar.custserv@dancon.com

Technical Support

Tel.: +1.800.234.8731

Fax: +1.847.782.5277

northstar.techsupport@dancon.com